

High Performance Computing in a Nutshell

HPC Services, RRZE / NHR@FAU

HPC systems at RRZE / NHR@FAU

<https://hpc.fau.de/systems-services/documentation-instructions/>

Parallel computing hardware terminology

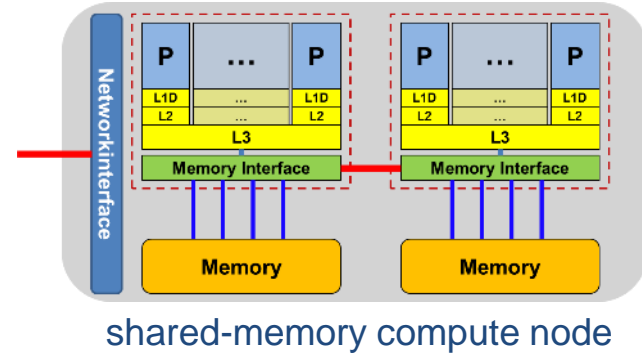
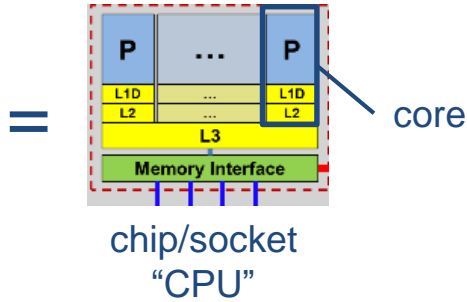

distributed-memory cluster

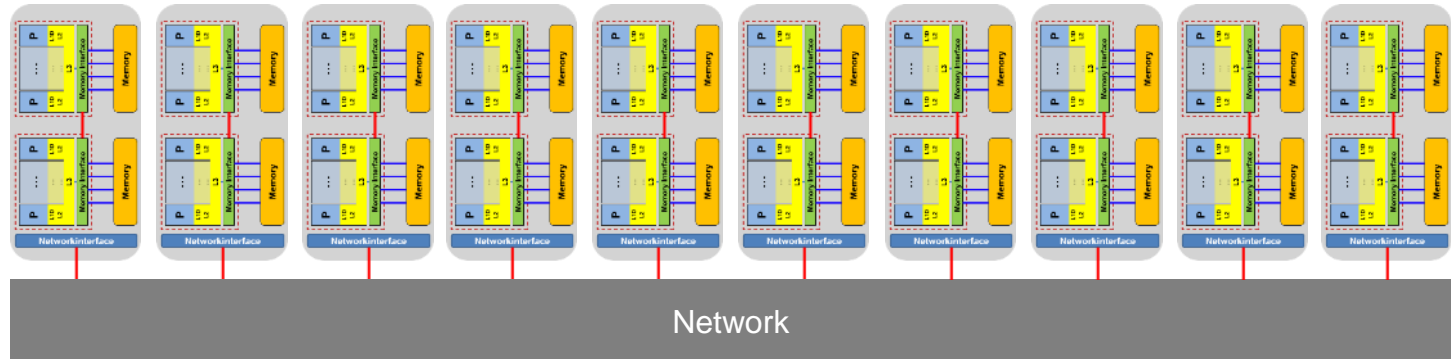

Which cluster should I use?

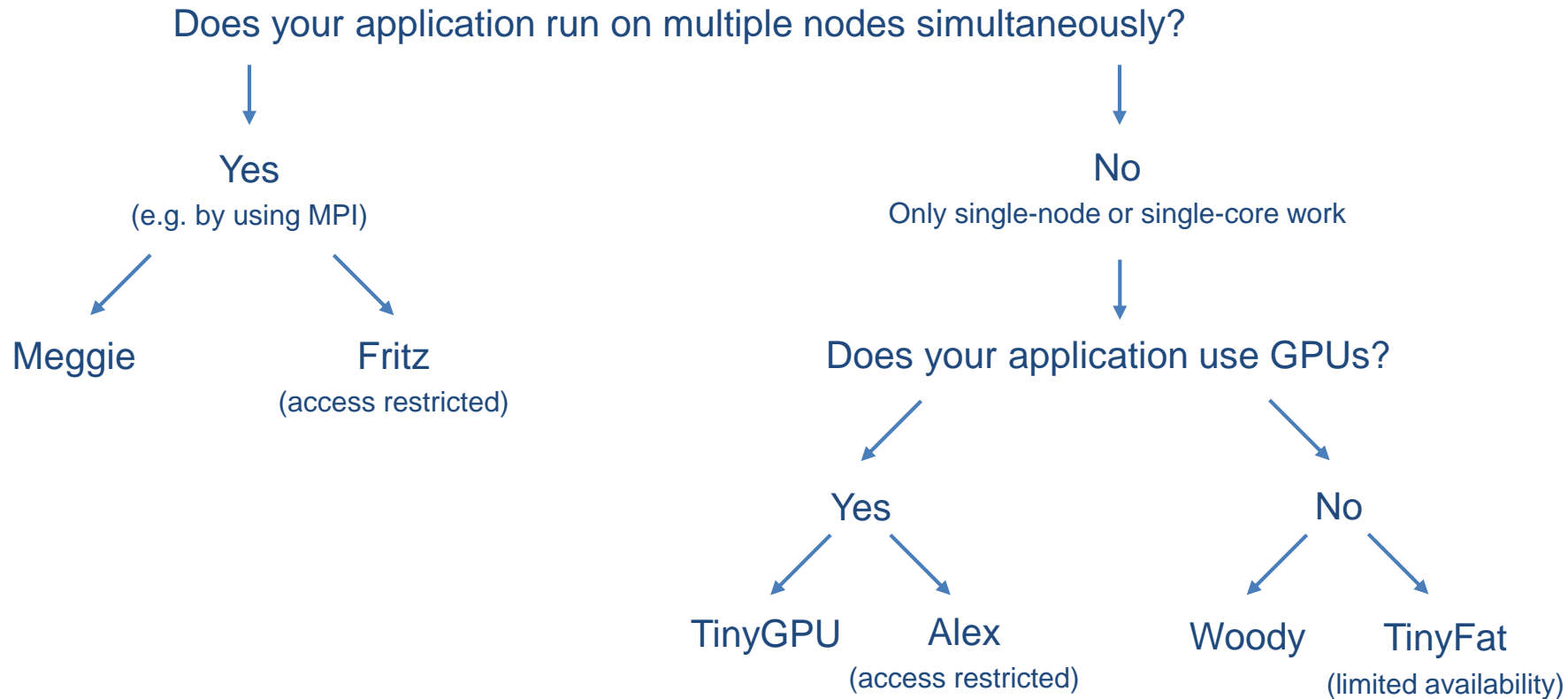

“Meggie” cluster

current main cluster for parallel jobs, intended for highly parallel jobs

- 728 Compute nodes (14.560 cores)
 - 2 Intel Xeon E5-2630 v4 (Broadwell) 2.2 GHz (10 cores)
 - 20 cores/node
 - 64 GB main memory
- No local disks
- Intel OmniPath network: Up to 100 Gbit/s



“Fritz” cluster

NHR&Tier3 parallel cluster, access restricted

- 992 compute nodes (71.424 cores)
 - 2 Intel Xeon Platinum 8360Y “Ice Lake”
2.4 GHz (36 cores)
 - 72 cores/node (SMT disabled)
 - 256 GB main memory per node
- Blocking (1:4) HDR100 Infiniband network, up to 100 GBit/s
- Parallel file system with 3,5 PB capacity

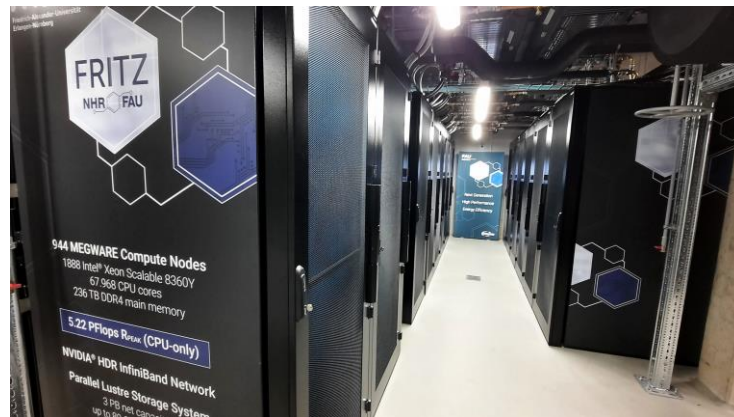

“TinyGPU” cluster

for GPU workloads – not all nodes always generally available

- 12 nodes with 2x “Skylake” @ 3.2 GHz, 96 GB RAM, 1.8 TB SSD, 4x RTX 2080Ti
- 4 nodes with 2x “Skylake” @3.2 GHz, 96 GB RAM, 2.9 TB SSD, 4x Tesla V100
- 7 nodes with 2x “Cascade Lake” @2.9 GHz, 384 GB RAM, 3.8 TB SSD, 8x RTX3080
- 8 nodes with 2x AMD Rome 7662 @2.0 GHz, 512 GB RAM, 5.8 TB SSD, 4x Volta A100



“Alex” cluster

NHR&Tier3 GPGPU cluster, access restricted

- 35 nodes with
 - 8x NVIDIA A100 (each 40 GB / 80GB HBM2)
 - 2x AMD EPYC 7713 “Milan” @2.0 GHz, 1024 GB / 2048 GB of main memory
 - 14TB local NVMe SSD
 - HDR200 Infiniband network
- 38 nodes with
 - 8x NVIDIA A40 (each with 48 GB DDR6)
 - 2x AMD EPYC 7713 “Milan” @2.0 GHz, 512 GB of main memory
 - 7 TB local NVMe SSD



“Woody” cluster

main workhorse for throughput and single-node jobs

- 176 nodes with 4 cores and high clock frequency (3.5/3.7 GHz) Intel Xeon E3-1240 v? processors
 - 64x Intel Skylake, 32 GB RAM
 - 112x Intel Kaby Lake, 32 GB RAM
- 70 nodes with 2x Intel Xeon Gold 6326 (32 cores total @2.9 GHz, 256 GB RAM)
- at least 960 GB local HDD/SSD
- Gbit network only



Accessing HPC systems

<https://hpc.fau.de/systems-services/documentation-instructions/ssh-secure-shell-access-to-hpc-systems>

HPC account - Non-NHR users

- You need a separate account (not your IdM account)
- Old HPC account application form in most cases still necessary
- Account can access all HPC systems except Alex and Fritz!
- Ask your local RRZE contact person for help
- If you change your affiliation, you need a new HPC account. Data migration may be required
- Password can be set/changed via IdM

Antrag auf Nutzung von HPC-Ressourcen am RRZE **HPC High Performance Computing** 

Antrag per FAX an 09131-85-2996
oder als Scan an 17241-10017241@rrze.fau.de
oder per (Hauptpost an RRZE-Servicecenter,
Münsterstr. 1, 91058 Erlangen)

Neuantrag Änderung/Verlängerung IDM-Account
(bestehender) HPC-Account

Antragsteller: Frau Herr Titel

Vorname _____
Nachname _____
E-Mail _____
Telefon _____
Nationalität(en) _____
HPC-Abteilung (bis DD.MM.JJJJ) _____

Auftraggeber: FAU-OrGNr. _____
Lehrstuhl- oder Institutsstempel und -verschrift _____
RRZE-Kontaktperson _____

Bei Unklarheiten ys@support.fuwi.fau.de kontaktieren

HPC-Systeme _____
typische Jobgröße _____
ingen. benötigte Rechenzeit _____
benötigter Speicherplatz _____

Art der Anwendung / Name der Applikation _____

Art/Finanzierung des Projekts _____

Abrechnung der Rechenzeit über bestehende Kundennummer neue Kundennummer für folgendes Rechenzeitprojekt

für jede neue Kundennummer
Titel des Forschungsvorhabens _____
für das Projekt insgesamt benötigte Rechenzeit _____
Bewilligungszeitraum / Projektlaufzeit _____
Fördernde Institution und Förderkennzeichen _____
Kurze Beschreibung der HPC-Aktivitäten im Forschungsvorhaben _____
Wurde der Rechenzeitbedarf mit dem RRZE abgestimmt und im Antrag dargestellt?
Haben die Gutachter der Förderinstitution dazu Stellung genommen?

Personenbezogene Daten im Sinne der geltenden Datenschutzgesetze dürfen unter dieser Benutzerkennung nicht ohne Sondergenehmigung seitens des RRZE und des Datenschutzbeauftragten verarbeitet werden!
Dem Antragsteller ist bekannt, dass er sich durch eine missbräuchliche Benutzung der Informationsverarbeitungssysteme strafbar machen kann und dass kein Vorliegen eines Missbrauchs grundsätzlich Strafanzug gestellt wird. Des Weiteren bemüht sich der Antragsteller, die HPC-Systeme effizient zu nutzen und gängige HPC-Praktiken zu beachten.

Benutzerrichtlinien:
<https://www.rrze.fau.de/infocenter/rahmenbedingungen/richtlinien/benutzungsrichtlinien/>

Antragsteller und Auftraggeber erklärt hiermit, von den Benutzerrichtlinien sowie den ergänzenden Hinweisen auf der Rückseite dieses Antrags Kenntnis genommen zu haben.

Ort, Datum _____ Unterschrift Antragsteller _____
_____ Unterschrift Auftraggeber/
_____ Kontaktperson _____
IDM-Kennung Auftraggeber/Kontaktpers. _____

HPC account - NHR users

- Account via portal.hpc.fau.de
- Invitation has to be send by project PI/technical contact
- Login to HPC portal with credentials of home institution via SSO
- No account passwords, cluster login only via SSH keys
- SSH keys can be managed over HPC portal

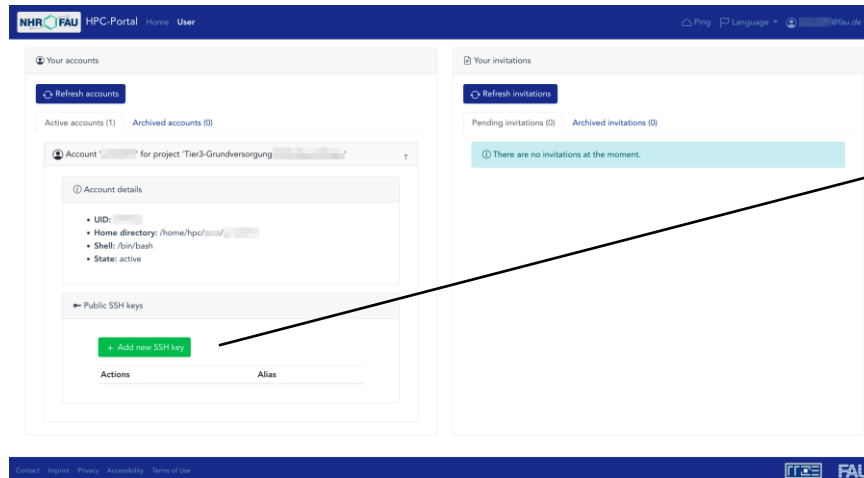
A detailed view of the 'Add new SSH key' form. At the top, there are 'Back', 'Submit', and 'Reset' buttons. The form is titled 'Public SSH keys' and 'Add new SSH key'. It contains several sections: 1. 'Alias': A text input field with the instruction 'Please enter an alias for this SSH key.' 2. 'Key Content': A large text area with the instruction 'Please enter the key content of this SSH key.' 3. 'Options': A section with a 'Hide advanced options' button. It includes: - 'Option 'from'' with a text input field and instruction 'Please enter a comma-separated list with IP addresses or hostnames for this SSH key.' - 'Option 'command'' with a text input field and instruction 'Please enter a command for this SSH key.' - A list of checkboxes for advanced options: 'Option 'no-pty'', 'Option 'no-agent-forwarding'', 'Option 'no-port-forwarding'', and 'Option 'no-X11-forwarding''.

Cluster access

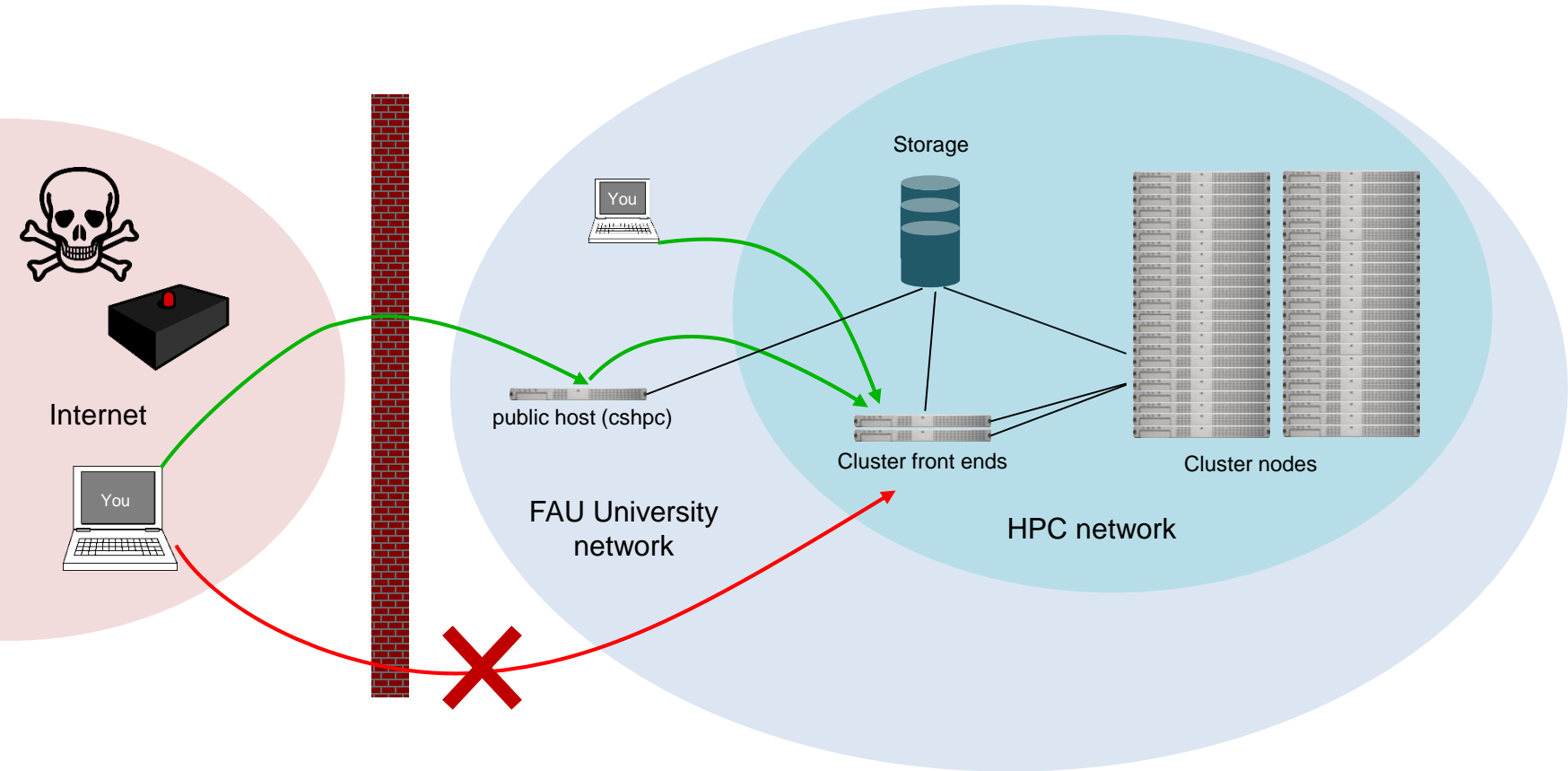

Cluster access

- Primary point of contact: cluster frontends
 - `meggie.rrze.fau.de`
 - `tinym.nhr.fau.de` (for TinyGPU/TinyFat)
 - `woody.nhr.fau.de`
 - `alex.nhr.fau.de`
 - `fritz.nhr.fau.de`
 - Only directly available from within FAU network or via IPv6
- Access from outside FAU network via dialog server
 - `cshpc.rrze.fau.de`
 - The only machine with a public IPv4 address

Secure Shell

- By default: text mode only

```
$ ssh ihpc02h@meggie.rrze.fau.de
```

- Basic knowledge of file handling, scripting, editing, etc. under Linux is required
- X11 forwarding with option `-X` or `-Y`
 - Requires local X server
- How to log into HPC systems:
<https://youtu.be/J8PqWUfkCrI>
- More information on ssh:
<https://hpc.fau.de/systems-services/documentation-instructions/ssh-secure-shell-access-to-hpc-systems>

Cluster access - NHR/HPC portal users

- Authentication only with SSH keys uploaded to HPC Portal, no passwords!
- Access to alex/fritz frontends from outside FAU:
 - directly via IPv6
 - by proxyjump over dialog server **csshpc.rrze.fau.de**
- Example for ssh-config:
https://hpc.fau.de/systems-services/documentation-instructions/ssh-secure-shell-access-to-hpc-systems/#ssh_config_hpc_portal

Secure Shell client programs

- Linux: OpenSSH available in any distribution
- Mac: ditto
- Windows
 - MobaXterm (<https://mobaxterm.mobatek.net/>)
 - includes an embedded X server
 - OpenSSH via Command/PowerShell
 - Linux Subsystem for Windows
 - WinSCP (data transfer only) (<https://winscp.net>)

Working with data

<https://hpc.fau.de/systems-services/documentation-instructions/hpc-storage/>

File systems

- File system == directory structure that can store files
- Several file systems can be “mounted” at a compute node
 - Similar to drive letters in Windows (C:, D:, ...)
 - Mount points can be anywhere in the root file system
- Available file systems differ in size, redundancy and how they should be used
- HPC Café on “Using file systems properly” (especially for data-intensive applications):
 - <https://hpc.fau.de/files/2022/01/2022-01-11-hpc-cafe-file-systems.pdf>
 - <https://www.fau.tv/clip/id/40199>

RRZE file systems overview

Mount point	Access	Purpose	Technology	Backup	Snapshots	Data lifetime	Quota
/home/hpc	\$HOME	Source, input, important results	NFS on central servers, small	YES	YES	Account lifetime	50 GB
/home/vault	\$HPCVAULT	Mid-/long-term storage	Central servers	YES	YES	Account lifetime	500 GB
/home/{woody, saturn, titan, janus, atuin}	\$WORK	General-purpose, small files	Central NFS server	NO	NO	Account lifetime	500 GB
/lxf /lustre	\$FASTTMP (only within fritz+alex)	High performance parallel I/O	Lustre parallel FS via InfiniBand	NO	NO	High watermark	Only inodes
/???	\$TMPDIR	Node-local job-specific dir	SSD/ramdisk	NO	NO	Job runtime	NO

File system quotas

- File system may impose quotas on
 - Stored data volume
 - Number of files and directories (inodes, actually)
- Quotas may be set per user or per group (or both)
- Hard quota
 - Absolute upper limit, cannot be exceeded
- Soft quota
 - May be exceeded temporarily (e.g., for 7 days – grace period)
 - Turns into hard quota at end of grace period

Displaying the quota limits

```
$ quota -s # generic command
Disk quotas for user unrz55 (uid 12050):
  Filesystem blocks quota limit grace files quota limit grace
10.28.20.201:/hpcdatacloud/hpchome/shared
      5544M 51200M 100G      72041 500k 1000k
wnfs1.rrze.uni-erlangen.de:/srv/home
      112G 318G 477G      199k 0 0

$ shownicerquota.pl # only on RRZE systems
Path Used SoftQ HardQ Gracetime Filec FileQ FiHaQ FileGrace
/home/hpc 5.7G 52.5G 104.9G N/A 72K 500K 1,000K N/A
/home/woody 112G 333.0G 499.5G N/A 188K N/A
```

Data transfer

- Most RRZE file systems are mounted at all HPC systems
 - Exception: parallel FS and node-local storage
- No NFS mounting from or to systems outside of RRZE
- → `scp` / `rsync` is the preferred file transfer tool from and to the outside

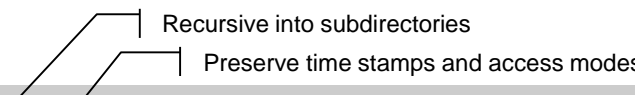

Recursive into subdirectories

Preserve time stamps and access modes

```
$ scp -r -p code unrz55@meggie.rrze.fau.de:/home/woody/unrz/unrz55
$ scp unrz55@meggie.rrze.fau.de:results/output.dat .
```

- Windows: <https://winscp.net/>

Software

<https://hpc.fau.de/systems-services/documentation-instructions/environment/>

The modules system

- Linux standard distro packages available on frontends and to some extent on compute nodes, but might be outdated
- Software provided locally by RRZE via modules system
 - Compilers, libraries, commercial and open software
 - Installed on central server and available on all cluster nodes
- A package must be made available in the user's environment to become usable
 - Command: **module**
 - All module commands affect the current shell only!

The module command

Show available modules: `module avail`

```
$ module avail
----- /apps/modules/data/applications -----
amber/20p12-at21p11-mpi-gnu          gromacs/2021.5-gcc11.2.0-mpi-mkl
amber/20p12-at21p11-mpi-intel       gromacs/2022.1-gcc11.2.0-mpi-mkl
amber/20p12-at21p11-openmpi-gpu-cuda gromacs/2022.1-gcc11.2.0-mkl-cuda
----- /apps/modules/data/compiler -----
gcc/10.3.0 gcc/11.2.0 gcc/12.1.0 intel/2021.4.0 intel/2022.1.0 nvhpc/22.1 nvhpc/22.2
----- /apps/modules/data/development -----
cuda/11.3.1          intelmpi/2021.4.0          openmpi/4.1.2-gcc11.2.0-cuda
cuda/11.4.2          intelmpi/2021.6.0          openmpi/4.1.2-intel2021.4.0-cuda
cuda/11.5.0          openmpi/4.1.2-gcc10.3.0-cuda openmpi/4.1.2-oneapi2021.4.0-cuda

$
```

The `module` command

Load a module: `module load <modulename>`

```
$ module load intel/2021.4.0
$ icc -V
Intel(R) C Intel(R) 64 Compiler Classic for applications running on Intel(R) 64, Version 2021.4.0 Build
20210910_000000
Copyright (C) 1985-2021 Intel Corporation. All rights reserved.
```

Display loaded modules: `module list`

```
$ module load openmpi/4.1.2-intel2021.4.0
$ module list
Currently Loaded Modulefiles:
1) intel/2021.4.0 <aL> 2) openmpi/4.1.2-intel2021.4.0
```

Module command summary

Command	What it does
module avail	List available modules
module whatis	Shows over-verbose listing of all modules
module list	Shows which modules are currently loaded
module load <pkg>/<version>	Loads specific version of module pkg, i.e. adjusts environment
module unload <pkg>	Undoes what the load command did
module help <pkg>	Shows a detailed description of pkg
module show <pkg>	Shows what environment variables pkg modifies and how

<https://hpc.fau.de/systems-services/documentation-instructions/environment/#modules>

Using Python

- Use anaconda modules instead of system installation

```
$ module avail python
----- /apps/modules/modulefiles/tools -----
python/2.7-anaconda  python/3.6-anaconda  python/3.7-anaconda(default)  python/3.8-anaconda
```

- Install packages via conda/pip with `--user` option
- Change default package installation path from `$HOME` to `$WORK`
- Build packages in an interactive job on the target cluster (especially for GPUs)
- It might be necessary to configure a proxy to access external repositories
- More details: <https://hpc.fau.de/systems-services/documentation-instructions/special-applications-and-tips-tricks/python-and-jupyter/>

Running jobs

<https://hpc.fau.de/systems-services/documentation-instructions/batch-processing/>

Interactive work on the front-ends

- The cluster frontends are for interactive work
 - Editing, compiling, preparing input,...
 - Front-ends are shared among all users, so be considerate!
 - Amount of compute time per binary is limited by system limits
 - E.g., after 1 hour of CPU time your process will be killed
 - MPI jobs are not allowed on front ends
- Submit computational intensive work to the batch system to be run on the compute nodes!
- Use interactive batch jobs for debugging and testing.

Batch System

- Users can interact with the resources of the cluster via the “Batch system”
- “Batch jobs” encapsulate:
 - Resource requirements (number of nodes, number of GPUs, ...)
 - Job runtime (usually max. 24 hours)
 - Setup of runtime environment
 - Commands for application run
- Batch system will handle queuing of jobs, resource distribution and allocation
- Job will run when resources become available



Example: Simple Slurm batch script

- Most simple batch script (job1.sh):

```
#!/bin/bash -l  
~/bin/a.out arg1 arg2 arg3
```

- Submission:

```
iww042@meggie1$ sbatch --nodes=1 --time=01:00:00 job1.sh  
1051341.madm
```



Example: Complex Slurm batch script

```
#!/bin/bash -l
```

```
#SBATCH --nodes=4 --ntasks-per-node=20 --time=06:00:00
```

```
#SBATCH --job-name=Sparsejob_33
```

Job submission options:
Nodes, cores per node, time, name,...

```
#SBATCH --export=NONE
```

Job option
sentinel

```
unset SLURM_EXPORT_ENV
```

```
# avoid login shell settings
```

```
# create a temporary job dir on $WORK
```

```
mkdir ${WORK}/${SLURM_JOB_ID}
```

```
cd ${WORK}/${SLURM_JOB_ID}
```

`$SLURM_*` variables contain
job-relevant data

```
# copy input file from location where job was submitted, and run
```

```
cp ${SLURM_SUBMIT_DIR}/inputfile .
```

```
srunk --mpi=pmi2 ${HOME}/bin/a.out -i inputfile -o outputfile
```

Actual run of your binary

Slurm batch job submission

```
iww042@meggie1$ sbatch job3.sh
```

```
Submitted batch job 357074
```

```
iww042@meggie1:~ $ squeue -l
```

```
Mon Jan 28 17:38:52 2022
```

JOBID	PARTITION	NAME	USER	STATE	TIME	TIME_LIMI	NODES	NODELIST (REASON)
357074	work	Testjob	iww042	RUNNING	0:35	1:00:00	4	m[0101-0104]

Specific for TinyFat/TinyGPU:

- All jobs are submitted from the frontend `tinyx.nhr.fau.de`
- Wrapper scripts have to be used for all Slurm commands (e.g. `sbatch.tinygpu`, `sbatch.tinyfat`, `squeue.tinygpu`, ...)

GPU Jobs on TinyGPU / Alex

- Nodes are shared, GPUs are always exclusive
- Granularity is one GPU with a corresponding proportion of CPU and main memory
- Request GPUs with **sbatch** option e.g.
 - `--gres=gpu:1` (if you don't care which type you get)
 - `--gres=gpu:rtx3080:1` (to request a specific type)
 - `--gres=gpu:a100:1 --partition=a100` (necessary for V100 and A100 GPUs on TinyGPU)
- More details and examples:
<https://hpc.fau.de/systems-services/systems-documentation-instructions/clusters/tinygpu-cluster>
<https://hpc.fau.de/systems-services/systems-documentation-instructions/clusters/alex-cluster/>

Interactive batch job with Slurm

- TinyGPU / Alex

```
iww042@tinysx$ salloc.tinygpu --gres=gpu:1 --time=01:00:00
```

```
iww042@alex1$ salloc --gres=gpu:a40:1 --time=01:00:00
```

- Meggie / Fritz:

```
iww042@meggie1$ salloc --nodes=1 --time=01:00:00
```

- Woody / TinyFat

```
iww042@woody$ salloc --ntasks=1 --time=01:00:00
```

```
iww042@tinysx$ salloc.tinyfat --cpus-per-task=10 --time=01:00:00
```

Slurm documentation

- NHR@FAU
 - General: <https://hpc.fau.de/systems-services/systems-documentation-instructions/batch-processing/>
 - Cluster-specific: <https://hpc.fau.de/systems-services/systems-documentation-instructions/clusters/>
 - HPC Café on “Slurm - basics, best practices and advanced usage”:
<https://hpc.fau.de/files/2022/04/2022-04-12-hpc-cafe-slurm.pdf>,
<https://www.fau.tv/clip/id/41306>
- Official Slurm documentation
 - Separate documentation for every command and the available options:
https://slurm.schedmd.com/man_index.html
 - Slurm commands and their counterparts in different batch systems:
<https://slurm.schedmd.com/rosetta.pdf>
 - Slurm tutorials: <https://slurm.schedmd.com/tutorials.html>

Some Dos and don'ts

Good practices

- Be considerate. Clusters are valuable shared resources that have been paid by the taxpayer.
- Use the appropriate amount of parallelism
 - Most workloads are not highly scalable
 - Best to run scaling experiments to figure out “sweet spot”
- Use the appropriate file system(s)
 - #1 mistake: Overload metadata servers by doing tiny-size, high-frequency I/O to parallel FS
 - Delete obsolete data

Good practices

- Check your jobs regularly
 - Are the results OK?
 - Does the job actually use the allocated nodes in the intended way? Does it run with the expected performance?
 - Check if your job makes use of the GPUs
 - Use ssh to log into a node where you have a job running
 - Use e.g. nvidia-smi to check GPU utilization
 - For pytorch/tensorflow, check if GPUs are detected
<https://hpc.fau.de/systems-services/systems-documentation-instructions/special-applications-and-tips-tricks/tensorflow-pytorch/>
 - Job Monitoring: <https://monitoring.nhr.fau.de/>
 - How to use it and what to look out for: <https://hpc.fau.de/files/2023/01/2023-01-10-HPC-Cafe-ClusterCockpit.pdf>

Good practices

- Talk to co-workers who are more experienced cluster users; let them educate you
- Do not re-use other people's job scripts if you don't understand them completely
- Look at tips and tricks for various applications (e.g. example batch scripts): <https://hpc.fau.de/systems-services/systems-documentation-instructions/special-applications-and-tips-tricks/>
- Have a look at HPC Café talks from past events: <https://hpc.fau.de/systems-services/support/hpc-cafe/>

Good practices

When reporting a problem to RRZE:

- Use the official contact hpc-support@fau.de – this will immediately open a helpdesk ticket
- Provide as much detail as possible so we know where to look
 - “My jobs always crash” will not do
 - Cluster, JobID, file system, time of event, ...
 - Batch script, output files, ...



THANK YOU.

HPC@RRZE / NHR@FAU

<https://hpc.fau.de>